

W. KRUTZSCH.

Tool-Holding Attachment for Metal-Lathes.

No. 166,787.

Fig. 1.

Patented Aug. 17, 1875.

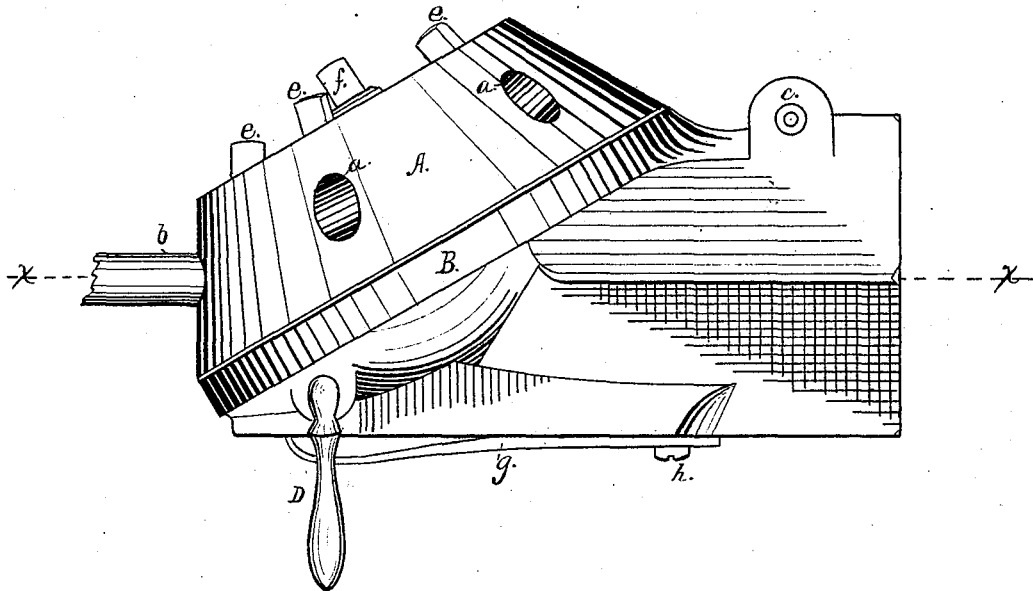
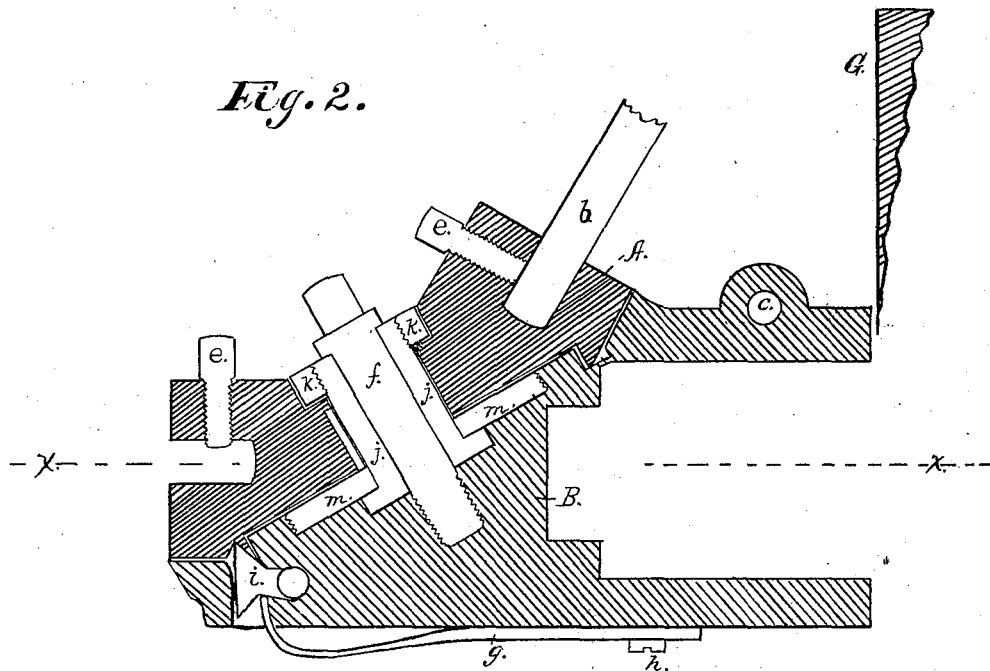

Fig. 2.



Witnesses;  
H. C. Mead.  
Albert Kern

Inventor;  
William Krutzsch  
by his Atty.  
Chas M. Peck

# UNITED STATES PATENT OFFICE.

WILLIAM KRUTZSCH, OF DAYTON, OHIO, ASSIGNOR TO GEORGE W. HOGLEN  
AND CHARLES E. PEASE, OF SAME PLACE.

## IMPROVEMENT IN TOOL-HOLDING ATTACHMENTS FOR METAL-LATHES.

Specification forming part of Letters Patent No. **166,787**, dated August 17, 1875; application filed  
April 15, 1875.

### *To all whom it may concern:*

Be it known that I, WILLIAM KRUTZSCH, of Dayton, in the county of Montgomery and State of Ohio, have invented new and useful Improvements in Tool-Holders for Lathe Attachments, of which the following is a specification:

The object of my invention is to provide an attachment to be clamped upon the mandrel of a metal-working lathe, that shall serve as a holder for several tools, either one of which, or each successively, may be used upon a piece of work without the usual delay in removing and substituting different tools.

In order to enable others skilled in the art to which my invention appertains to make and use the same, I would thus describe it, referring to the accompanying drawings, in which—

Figure 1 is a side elevation of my improved apparatus. Fig. 2 is a longitudinal central section of the same.

B represents the body of my improved attachment, with a hollow shank to fit upon the mandrel of a lathe, to which it is secured by a clamp-screw passing through ears *c*, or in any convenient manner. The forward part of this body is a circular bearing-face, inclined at an angle of about thirty degrees with the axis of the lathe. I say thirty degrees, but the angle may be greater or less without interfering with the application of the principle embodied. The center of the circular face must be cut by the axis of the mandrel, and upon the face is secured, in the manner I shall presently point out, the frustum of a cone, A, whose radial plane, in which the axis lies, has its outside edge, or its edge corresponding with the face of the cone, at right angles to the axis of the mandrel, indicated by the dotted lines *x x*.

I do not wish to confine myself to the particular manner of securing the frustum to the inclined face, but suggest as best that represented in Fig. 2, in which a hollow pivot-bearing, *j*, with a shoulder or flange at its bottom, is passed through an annular disk, *m*, screwed into the bearing-face. The flange fits snugly, but free to be turned, into a corresponding recess in the face. The frustum with a central opening is slipped upon the bearing *j*, to which it is keyed, and a ring, *k*, acting as a jam-nut, is screwed upon the top of the same bearing.

A pivot, *f*, at right angles to the plane of the bearing-face, is passed through the part *j*, and is secured in the body B. By tightening or loosening this pivot the frustum can be properly adjusted, so as to be turned with ease. A latch, *i*, with a handle, D, is pivoted in the body B, and is held by a spring, *g*. In the face of the frustum are recesses *a*, sunk at right angles to the face, and so located that as the frustum is revolved the centers of these recesses shall successively correspond with the axis of the lathe mandrel. Tools *b*, for performing various descriptions of work, are secured in the recesses by the set-screws *e*. Under each recess is a slot in the frustum engaging with the latch *i*, and by means of which the frustum is locked at any point, and held rigidly.

The particular advantage to be gained by the inclined frustum is, that in revolving it the projecting tools are inclined, as seen at *b*, Fig. 2, and do not come in contact with the puppet-head of the lathe, (represented by G,) while at the same time the tool at work is so near the mandrel that it is perfectly rigid and not liable to spring.

Another essential advantage is, that different tools secured in the frustum may be brought to bear upon the same piece of work in rapid succession without any of the delay or difficulty consequent upon removing one and substituting another tool, as is the case in ordinary lathes.

Having fully described my invention, I claim and desire to secure by Letters Patent—

1. For attachment to the mandrel of a lathe, the tool-carrying frustum A and body B, the former attached to the latter at an angle, substantially as described.

2. The herein-described improved attachment, consisting of the body B, latch *i*, pivot *f*, bearing *j*, disk *m*, ring *k*, and frustum A, provided with recesses *a* and set-screws *e*, all substantially as described, and for the purpose specified.

Witness my hand this 8th day of April, A. D. 1875.

WILLIAM KRUTZSCH.

Witnesses:

E. THOMPSON,  
CHAS. M. PECK.